

SEQUANS
COMMUNICATIONS

PMC
PMC-SIERRA

An Analysis of the Benefits of Uplink MIMO in Mobile WiMAX Systems

June 2008

SEQUANS Communications

Bilel Bouraoui, Amélie Duchesne, Bertrand Muquet, Ambroise Popper

PMC-Sierra

Peter Stewart, Ben Lake

Executive Summary:

This paper discusses the improvements that uplink MIMO brings to Mobile WiMAX network deployments and introduces a new technique based on uplink MIMO, tile switched diversity (TSD). Uplink MIMO (UL-MIMO) provides extended coverage (up to 41 percent cell radius increase), and can also be used to reduce power consumption (up to 750 mW power savings) and greatly ease design constraints for high output power CPEs. Maximum performance is obtained when UL-MIMO is implemented both at the mobile station and the base station, but this analysis shows that significant gains can be achieved with UL-MIMO implemented at the mobile station only.

Introduction	3
1 End-to-End Uplink MIMO.....	4
1.1 STC Matrix A	4
1.2 STC Matrix B	5
1.3 Collaborative MIMO	6
2 Mobile Station Uplink MIMO	7
2.1 Cyclic Delay Diversity (CDD)	7
2.2 Tile Switched Diversity (TSD)	8
3 Performance of Uplink MIMO schemes	10
3.1 Combining Gain	10
3.2 Fading Margin Reduction.....	10
3.2.1 Fading Environments	10
3.2.2 Near Line-of-Sight Environments	12
3.3 Summary	12
4 Benefits	13
4.1 Reduction of Power Consumption / Cost	13
4.1.1 Scenario	13
4.1.2 Power reductions.....	14
4.1.3 Relaxed RF constraints	14
4.1.4 Cost Reduction.....	14
4.1.5 Impact on board size	14
4.2 Increased Coverage	15
4.2.1 Scenario	15
4.2.2 WiMAX link budget imbalance.....	15
4.2.3 Enhancement to coverage thanks to diversity gain and combining gain.....	16
4.2.4 Increased Capacity.....	16
4.2.5 Cost and Size impact	16
Conclusion	18
References.....	19

Introduction

The promise of WiMAX to end users is its ability to provide truly mobile broadband services to great numbers of people across markets, geographies, and cultures. The promise of WiMAX to operators is its ability to provide new revenue streams to a wide range of service providers, from WISPs (wireless internet service providers) seeking to offer wireless DSL-type service in rural and emerging markets, to large mobile network operators seeking to complement voice service with high-speed mobile broadband data services in urban and developed markets.

Today, WiMAX is rolling out in rural areas such as India, where it is being deployed by leading operators to deliver fixed and nomadic voice and data communications. It is also being deployed in ultra dense urban areas by leading operators, in the United States and Japan, focused on providing mobile broadband services beyond voice.

To fulfill the WiMAX promise, WiMAX semiconductor platforms should provide solutions for all types of WiMAX equipment makers and service providers in all markets. However, to meet the requirements of extended coverage, high data rate, and low power consumption, silicon solutions need to deliver some challenging tradeoffs necessary presented by these key constraints.

In WiMAX systems, as in other wireless systems, the uplink channel can be a bottleneck. Improving the uplink performance yields benefits for both operators and end users; it lowers infrastructure costs and improves user experience. Typically in current WiMAX systems, MIMO (multiple input multiple output) is implemented on only the downlink channel. Uplink MIMO, the implementation of dual transmit channels in a single user terminal, is one of the WiMAX capabilities that can improve uplink performance.

Moreover, if an appropriate algorithm is used in implementing the second transmit channel, substantial improvement can be achieved with little or no incremental cost to the mobile station and no cost at all to the base station.

1 End-to-End Uplink MIMO

There are several techniques specified in the IEEE 802.16e-2005 standard that can be used to perform end-to-end MIMO on the uplink:

STC Matrix A. This scheme is often referred to as the Alamouti scheme [1][2]. It is part of the WiMAX profile R1.0, but for the downlink only, and is commonly used as a means to provide diversity. In the standard, it is also specified for the uplink. However, it is currently not included in the profile since it requires the mobile station to be equipped with 2 Tx antennas.

STC Matrix B. This scheme enables a single user device to spatially multiplex its transmitted data, thus allowing an increase in the actual user data throughput over the link. It is part of the WiMAX profile R1.0 for the downlink and is commonly used as a means to increase the user data throughput and cell capacity. It can also be used on the uplink though it is not required by the profile.

Collaborative MIMO. This scheme enables an operator to spatially multiplex two different users in the uplink. This does not double the instantaneous user data rate but increases the cell capacity on the uplink. It is currently part of the profile since it does not require the mobile station to be equipped with 2 Tx.

All three of these techniques require the base station to support a specific MIMO receiver.

1.1 STC Matrix A

Matrix A is a space time code scheme based on the well-known scheme introduced by Alamouti in [2]. It enables a high order of diversity in a simple manner.

The following graph illustrates the STC Matrix A scheme. Two information symbols s_1 and s_2 are transmitted over a period of 2 symbols and sent using a specific coding between the two antennas:

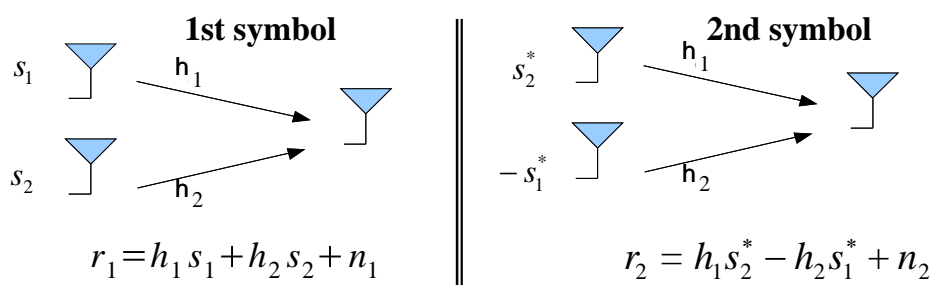

The receiver can apply proper decoding so as to retrieve the originally sent signals:

$$x_1 = h_1^* r_1 - h_2 r_2^* = (|h_1|^2 + |h_2|^2) s_1 + h_1^* n_1 - h_2 n_2^*$$

$$x_2 = h_2^* r_1 + h_1 r_2^* = (|h_1|^2 + |h_2|^2) s_2 + h_2^* n_1 + h_1 n_2^*$$

Diversity lowers the probability of channel fading by transmitting the signal through independent channels. When Matrix A is used with a simple one antenna receiver, order-2 diversity is achieved. Indeed when the antennas are sufficiently spaced so that the channels are independent, the probability of deep fading on $(|h_1|^2 + |h_2|^2)$ is much smaller than on $|h_1|^2$.

When Matrix A is used with a 2-antenna receiver at the base station, implementing maximum ratio combining (MRC), order-4 diversity can be achieved. The probability of deep fading is much smaller with $(|h_{11}|^2 + |h_{12}|^2 + |h_{21}|^2 + |h_{22}|^2)$ than with $|h_1|^2$.

STC Matrix A therefore provides the following benefits:

- When used with a simple one antenna receiver, order-2 diversity is achieved.
- When combined with MRC, order-4 diversity is achieved.

1.2 STC Matrix B

STC Matrix B is a spatial multiplexing MIMO scheme where two streams of symbols from both transmit antennas are transmitted simultaneously, as illustrated by the following graph:

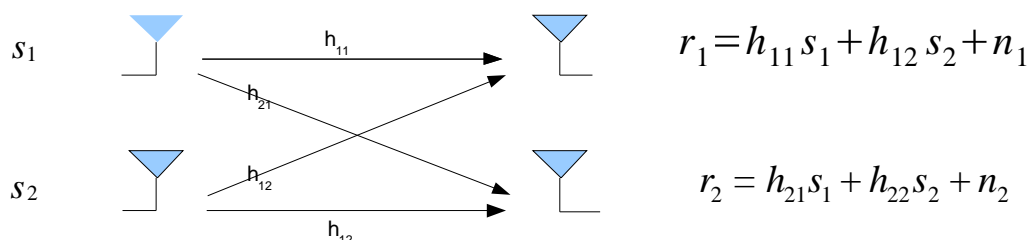

Decoding the stream of transmitted symbols requires that the channels be sufficiently de-correlated. Several decoder options are available, and the best performance is achieved with a maximum likelihood (ML) decoder. Sequans has implemented a maximum likelihood decoder as part of its patent-pending *mimoMAX*TM technology. Further explanation can be found in [3]. Note that this scheme requires 2 Rx antennas.

The following benefits can be achieved with STC Matrix B:

- Double the rate of transmission
- Deliver order-2 diversity (indeed s_1 and s_2 are received through the 2 Rx antennas and hence through 2 independent fadings)

1.3 Collaborative MIMO

Collaborative MIMO is a scheme introduced in [1], which consists of implementing spatial multiplexing between two different mobile stations, instead of between the two antennas of a given mobile station. This is illustrated in the following graph:

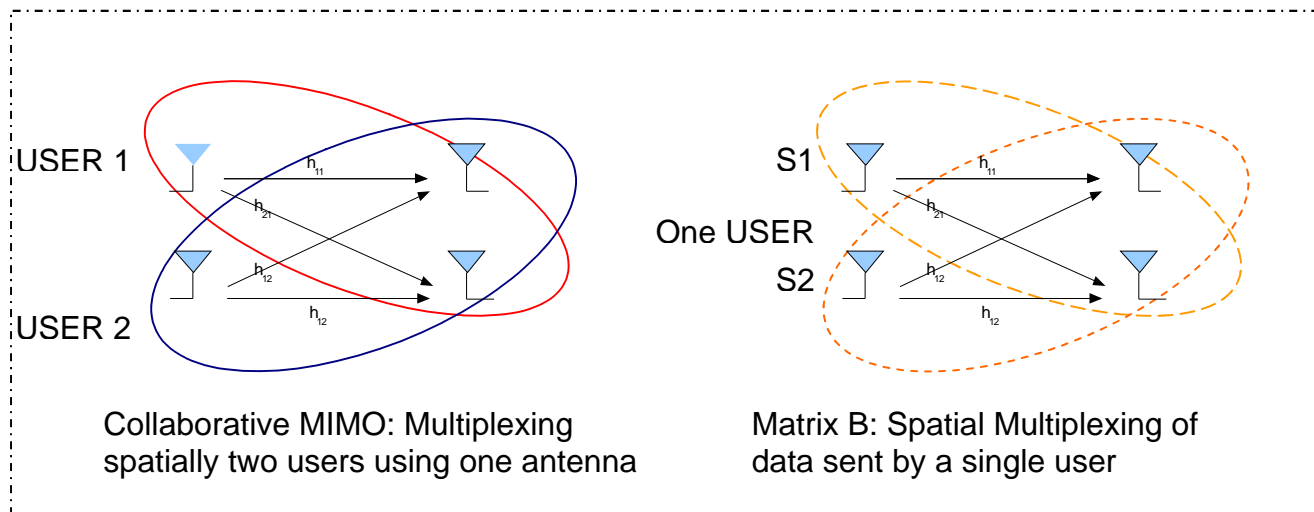

Collaborative MIMO provides benefits similar to STC Matrix B:

- Double the rate of effective transmission from a cell capacity perspective. Note that the user rate is not increased.
- Deliver order-2 diversity since the data transmitted by one user is received through 2 Tx antennas.

2 Mobile Station Uplink MIMO

When defining Mobile WiMAX profile R1.0, priority was put on implementing downlink MIMO, and limiting the number of Tx antennas at the mobile station side to one antenna only, so the support of matrices A and B are not mandated for the base station receiver.

Therefore, it is interesting to consider alternative uplink techniques that do not require any support from the base station. These techniques must be able to operate with any base station and not interfere with other schemes.

We present here two such techniques:

Cyclic Delay Diversity (CDD): this is a well-known technique [4] that is used in many technologies to provide additional diversity. It is also used in WiMAX on the downlink in many implementations, especially for the 1st PUSC SISO zone on which the use of matrices A and B is precluded by the standard. CDD performs well mostly in fading environments but raises many issues in line-of-sight (LOS) or near-LOS environments since it creates interference.

Tile Switched Diversity (TSD): this is a novel technique developed by Sequans, introduced here, that compares favorably to CDD, as it has greater or equal performance in fading environments and significantly better performance in environments with a line-of-sight (LOS or NLOS).

Both of these techniques require the implementation of two transmit antennas at the mobile station but are fully transparent to the base station. Of course, they can be further enhanced by the use of MRC at the base station.

2.1 Cyclic Delay Diversity (CDD)

Cyclic delay diversity sends a delayed version of the signal on a second antenna, as illustrated below:

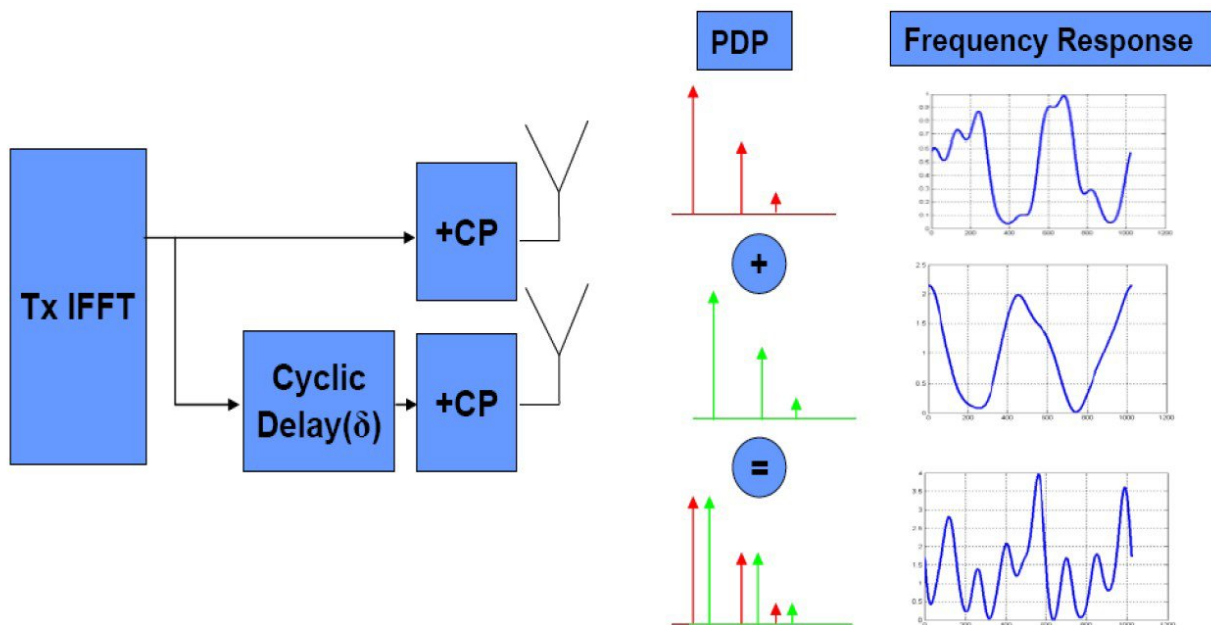

It is a simple way of adding diversity to a system, and performs well in fading environments [4].

CDD transmits a delayed version of the signal on the second Tx antenna that the receiver will exploit. This is enabled by the OFDM structure and the convolutional encoder. The downside of CDD is that it can actually degrade performance in line-of-sight, or near line-of-sight environments. However, this degradation could be reduced if CDD is advertised to the receiver. This would require modifications at the base station in addition to modifications in the standard for signaling it to the base station.

2.2 Tile Switched Diversity (TSD)

Tile switched diversity is a novel scheme where tiles from data slots are split between the two transmit antennas of the mobile station:

- Each uplink slot (group of 6 tiles) is split in two groups of three tiles.
- Each group of tiles goes to a different transmit antenna, and therefore is affected by a different channel.
- This is completely transparent to the base station, as channel estimation is done on a slot-by-slot basis

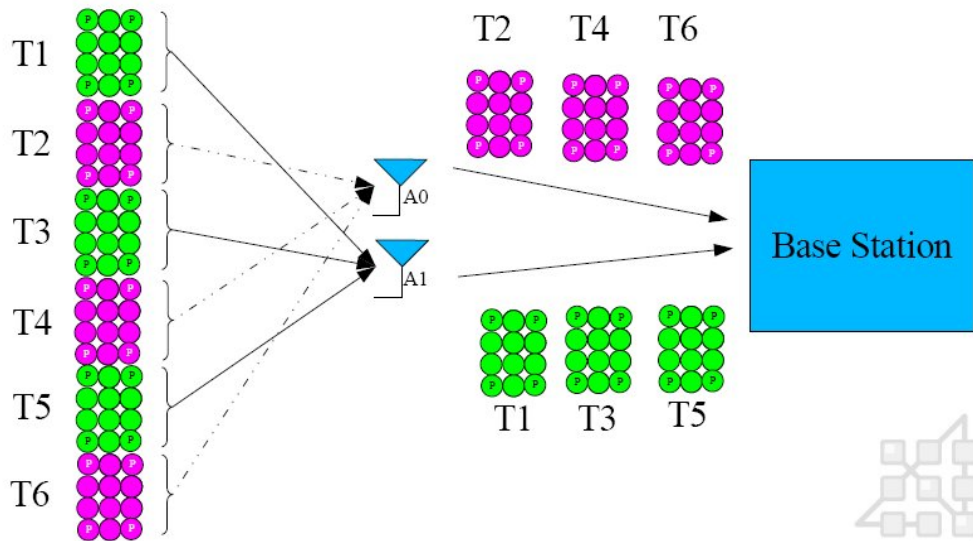

Because coding is performed on a slot-by-slot basis, the diversity introduced by TSD on the tiles will be exploited by the convolutional encoder to reduce the error probability. The exact order of diversity is directly a function of the coding order. Furthermore, a TSD scheme can be further enhanced by the use of MRC at the base station.

TSD is superior to CDD in several respects:

- Unlike CDD, TSD does not degrade performance in LOS or near-LOS environments.
- With TSD, no interference phenomenon is created since a tile is never transmitted simultaneously by the two Tx antennas.
- TSD does not raise synchronization ambiguities as CDD does where the OFDMA signal is transmitted with different delays on the two Tx antennas, making synchronization more difficult.
- TSD does not decrease the coherence bandwidth of the actual channel and therefore does not incur any channel estimation performance degradation.

All this makes TSD very robust and simple.

3 Performance of Uplink MIMO schemes

3.1 Combining Gain

Due to the physical combination of the transmit signals from both antennas over the air, the resulting power of the transmitter is equal to the sum of the power transmitted on each antenna. Thus, if the power transmitted on each antenna is the same, UL-MIMO schemes provide a 3 dB combining gain in the link budget. This combining gain is present with whatever uplink MIMO scheme is used (end-to-end or mobile station only).

3.2 Fading Margin Reduction

3.2.1 Fading Environments

The following graphs illustrate the performance gains of TSD and STC Matrix A over simple MRC. All the curves present FEC block error rate where FEC block have a packet size of 36 bytes as specified in the standard. They have all been run according to the ITU and SUI channel models that are used in the standard. Furthermore, to keep comparisons fair, the performance is that of a base station implementing a floating point receiver with perfect channel knowledge.

The figure below compares the performance of 1Tx (no UL-MIMO), TSD and STC Matrix A on the ITU pedestrian channel model B (used for WiMAX conformance tests). It can be observed that TSD brings an important diversity gain that will noticeably enhance the system performance. For instance, at an FEC block error rate of 10^{-4} (an FEC block being a packet of 36 bytes), the difference in performance is 2dB. Moreover the performance of TSD is very close to that of STC. Note that though CDD has not been depicted on this figure, it gives performance close to TSD in such a context.

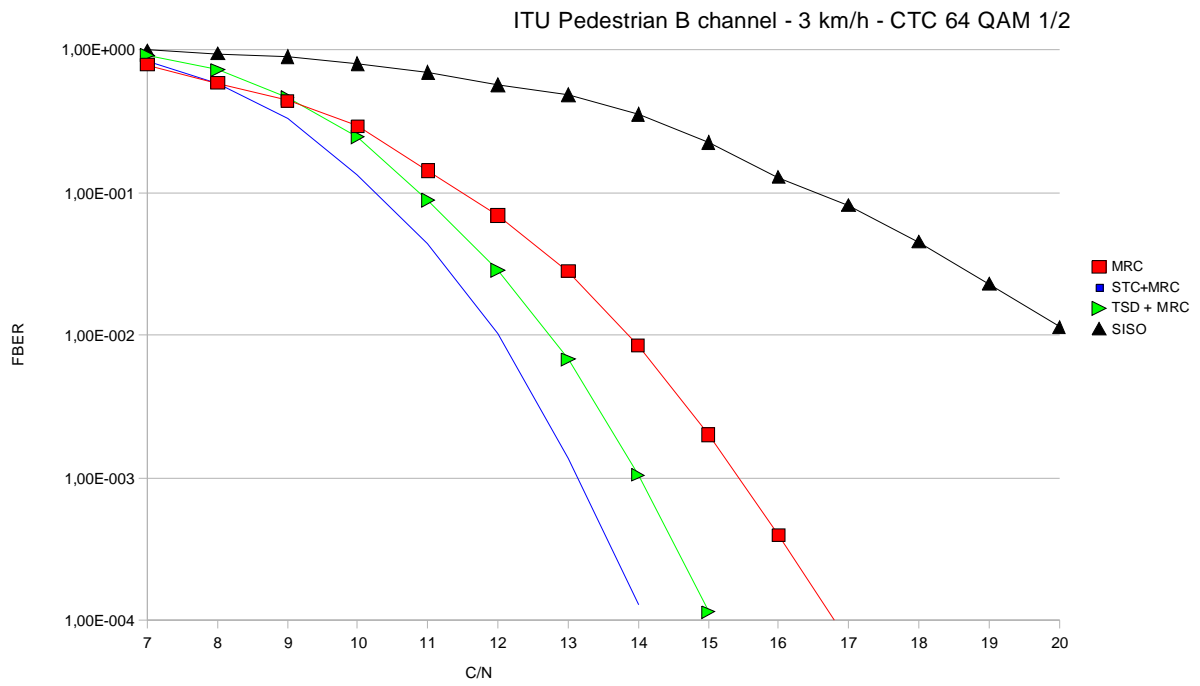

On a typical vehicular channel, representing mobile terminals, the conclusions remain unchanged: TSD brings a level of diversity between that of 1Tx+MRC and that of STC + MRC.

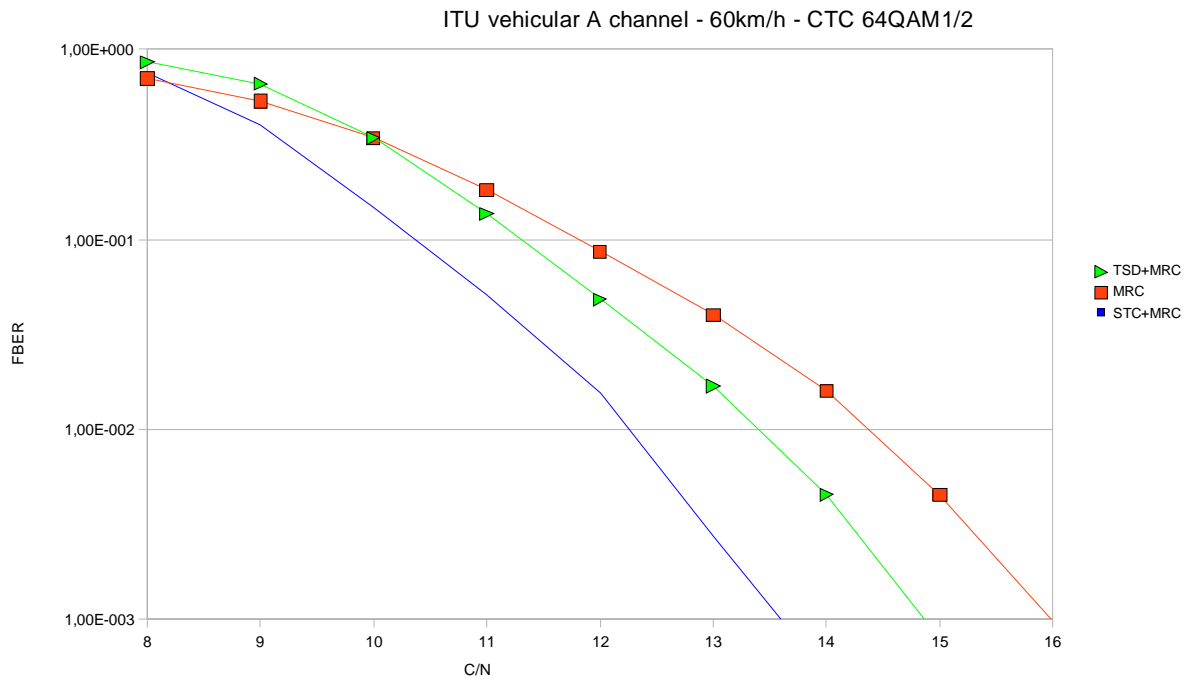

3.2.2 Near Line-of-Sight Environments

On a near line of sight channel such as the SUI 1 channel model, the performance enhancement brought by TSD is dramatic. Once again it is very close to the optimum diversity solution, STC Matrix A, although it does not require any base station change.

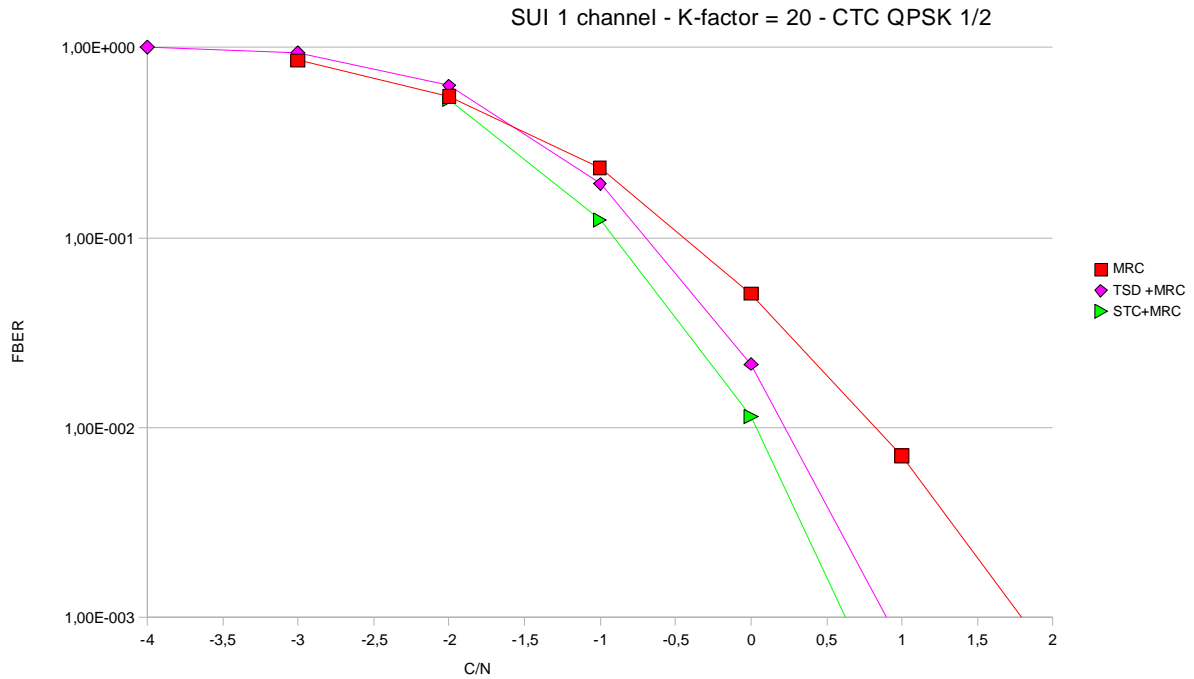

3.3 Summary

The UL-MIMO techniques provide the following gains on the uplink link budget (based on PedB results):

- 3 dB combining gain
- 2 dB fading margin gain for TSD, and 3 dB fading margin gain for STC Matrix A

The following section will analyze how this 5 to 6 dB link budget gain can benefit actual designs.

4 Benefits

The performance gains shown in the previous sections can be translated in various alternative ways:

Power consumption: up to 750 mW power reduction

Increased coverage: up to 41 percent cell radius extension

4.1 Reduction of Power Consumption / Cost

In WiMAX networks, transmit power at the mobile station is a critical parameter, particularly in battery-powered devices. A significant portion of the power consumption of the device is due to the power consumed by the transmit power amplifier (PA). UL-MIMO techniques can provide a significant power reduction by enabling dual-transmit terminals to transmit at a lower power, while maintaining performance equivalent to single transmit terminals.

4.1.1 Scenario

We compare here the power consumption of the following terminals:

- A single-transmit terminal with an output power of 28 dBm
- A dual-transmit terminal with an output power of 23 dBm for each branch

Both terminals have equivalent link budgets because when combining the 2 transmitters at 23 dBm, an additional 3 dB combining gain and 2 dB diversity gain must be added, resulting in an equivalent link budget of 28 dBm.

2 Tx CPE @ 23 dBm

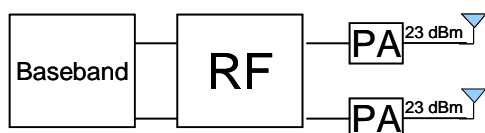

vs.

1 Tx CPE @ 28 dBm



Considering that the dual-transmit terminal is implementing TSD, both terminals have equivalent performance in terms of link budget.

4.1.2 Power reductions

By analyzing data available for a wide range of power amplifiers (PAs), we estimate the average power to be 1450 mW (considering a duty cycle of 1/3). For output powers of 23 dBm, it is possible to use more efficient PAs. By summing the power of the two PAs, we estimate the average power to be 650 mW, i.e a reduction of 800 mW.

On the baseband and RF side, the power difference between the UL-MIMO enabled terminal and the SISO terminal adds an estimated 50 mW.

In the case of using mobile station-only techniques (TSD), this shows an average gain of 750 mW,. Gains using end-to-end MIMO, such as Matrix A, would be even higher.

4.1.3 Relaxed RF constraints

Another benefit of using a PA with lower transmit power is that thermal dissipation is far lower. This means that in the case of a high output-power terminal, the heat sink may be removed. This presents a significant reduction in board size and bill-of-materials.

In addition, various RF requirements such as transmit error vector magnitude (EVM), spectral masks or control of spurious emissions, can be more easily met, greatly simplifying the design of the terminal.

4.1.4 Cost Reduction

It is difficult to provide exact pricing, but we estimate the following prices for the RF sections:

Dual-transmit: we estimate the price of the front-end section to be about \$4 for 500K volumes.

Single-transmit: due to the high output power of this scenario, the cost of the PA component is much higher, resulting in an overall cost for the front-end of \$5 for 500K volumes

Result: A \$1 saving on the bill-of-material (BOM) when using UL MIMO.

4.1.5 Impact on board size

Based on currently available data, the board space required for two smaller PA components is between 40 and 70 percent of the board space required for a single higher power PA. The total physical size for all components for both transmit paths is between 60 and 90 percent of the single higher power PA. In the worst case, the two design approaches would have essentially the same physical size. Further physical size reductions will become available as more integrated RF front-end offerings (e.g. dual-PA

products, integrated modules) are introduced in the market. Obviously, a smaller PA die will be easier to integrate into such modules.

Note that this size impact assumes the use of an RFIC with 2 Tx and 2 Rx chains.

4.2 Increased Coverage

4.2.1 Scenario

We compare here an UL-MIMO enabled mobile station, using power amplifiers (PAs) with an output power of 23 dBm, to a mobile station with a SISO transmitter at an output power of 23 dBm:

2 Tx CPE @ 23 dBm

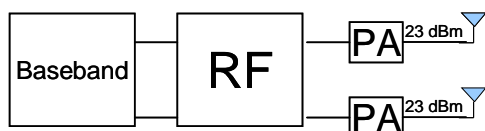

1 Tx CPE @ 23 dBm

vs.



4.2.2 WiMAX link budget imbalance

In WiMAX systems, as in many other radio systems, the difference in transmit power between the base station and the mobile station is quite important. Typical transmit power of base stations is 40 dBm, and of mobile stations is 23 dBm. This creates a de-facto link budget imbalance between the downlink and the uplink. Other factors must be taken into account to calculate the overall link budget imbalance, in particular:

- Subchannelization gain of the uplink
- Downlink boost for remote users
- Additional gain provided by the use of downlink MIMO
- Number of Rx antennas at the base station

Overall, we estimate the typical link budget imbalance in a WiMAX system to be 6dB. This imbalance can be exploited by operators to provide asymmetric services (typically data services require more downlink than uplink throughput), but in many cases the imbalance is the limiting factor in the uplink in terms of coverage. For this reason, 64QAM is optional in the uplink in the WiMAX Forum profile.

4.2.3 Enhancement to coverage thanks to diversity gain and combining gain

The link budget enhancements provided by uplink MIMO can translate directly to increased cell coverage, considering that the uplink is the limiting factor:

- When using STC Matrix A, the 6 dB link budget translates to a **41 percent cell radius increase** and a **99 percent cell area increase**.
- When using TSD, the 5 dB link budget translates to a 33 percent cell radius increase and a 78 percent cell area increase.

4.2.4 Increased Capacity

The additional uplink link budget can alternatively be used to increase the capacity. Depending on the scheduling policy used by the base station, this can be achieved in different ways:

Higher overall capacity. Uplink MIMO can improve the cell capacity by enabling mobile stations to transmit in a higher modulation and coding scheme (MCS); therefore, for the same quantity of transmitted data, less radio resource is occupied. The freed radio resource can in turn be allocated to other terminals. With this scheduling policy, more users can be serviced on the uplink (with the same average rates). This additional capacity enables operators to serve more customers for a given number of base stations, in environments that are limited by capacity, thus providing direct impact on operational expenses.

Higher individual throughput. An alternative scheduling policy is to use the additional uplink link budget to provide higher throughput to users (as opposed to sharing the capacity with more users). This can be used by operators to provide premium services to users requiring higher throughput on the uplink (typically professional users).

4.2.5 Cost and Size impact

The following figure illustrates a typical mobile station RF front-end design (passives for power supply decoupling are omitted for clarity):

In green are the main components of a 1Tx/2Rx mobile station.

In orange are the additional components for a 2Tx/2Rx mobile station (a second power amplifier, filters and diplexer).

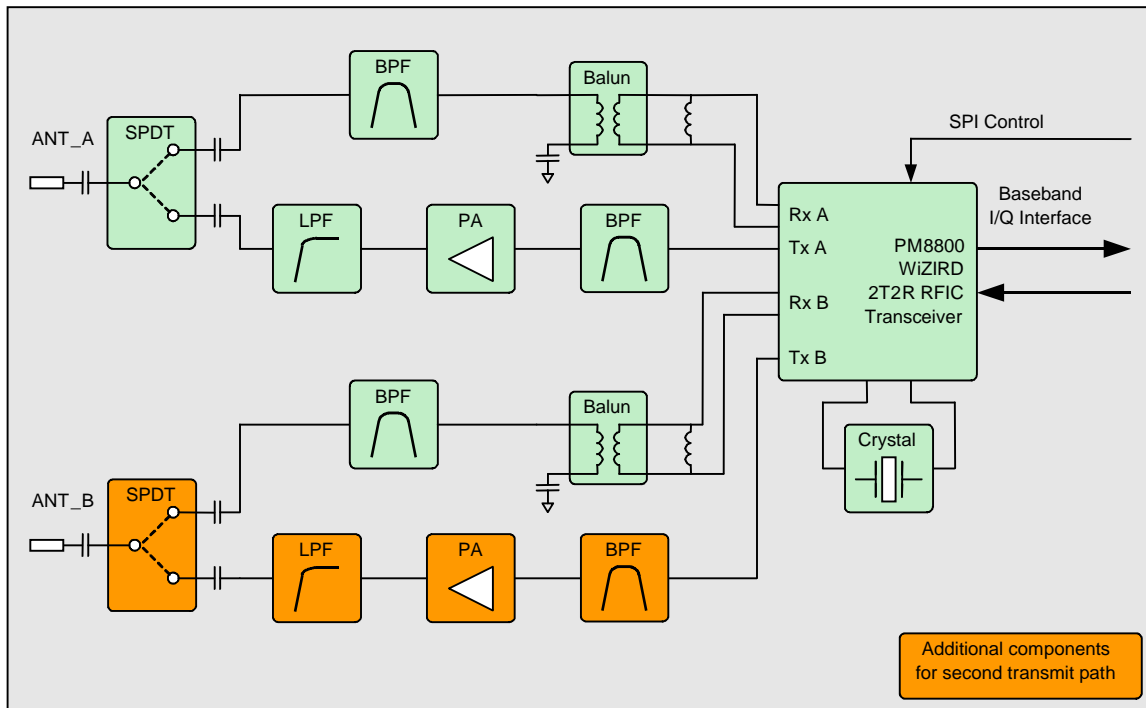

The additional size required for the additional components is approximately 50 mm² (this will vary depending on the components chosen). In the future, this could even be smaller, as integrated front-end modules (FEM) are used. Note that some FEM vendors are planning integrated dual-FEM designs in a single package. This process would further reduce the impact of the second transmitter.

Similarly, it is difficult to provide exact price estimates due to variable vendor pricing. Nevertheless, we estimate the added cost of the second transmitter in this case to be about \$2 in 500K volumes.

Conclusion

This paper introduces various techniques for uplink MIMO and compares their benefits, while analyzing the impact on the cost of terminals.

As a summary, the implementation of two transmitters at the mobile station can provide the following gains on the link budget:

- 6 dB using end-to-end MIMO (STC Matrix A).
- 5 dB using mobile station-only MIMO (TSD).

This directly translates into the following gains:

- Lower power/cost: up to 750 mW in power consumption reduction, and \$1 cost reduction.
- Increased coverage: up to 41 percent cell radius increase.

References

- [1] IEEE 802.16-2005: IEEE Standard for Local and Metropolitan Area Networks – Part 16: Air Interface for Fixed and Mobile Broadband Wireless Access Systems – Amendment 2: Physical Layer and Medium Access Control Layers for Combined Fixed and Mobile Operation in Licensed Bands, February 2006.
- [2] S. M. Alamouti, "A Simple Transmit Diversity Technique for Wireless Communications," IEEE Journal on Selected Areas in Communications, vol. 16, no. 8, pp. 1451 – 1458, October 1998.
- [3] B. Muquet, E. Biglieri, A. Goldsmith, and H. Sari, "MIMO Techniques for Mobile WiMAX Systems", www.sequans.com, 2005
- [4] Y.Li, J Chuang, N. Sollenberger, IEEE JSAC, Vol17, No 7, July 1999, "Transmitter diversity and its impact on OFDM systems"